



Product Warranty Card

Name: _____
Address: _____
Date of Purchase: _____
Purchase from: _____
Product: TMS Oxygen Concentrator
Model: 7F-5
S/N: _____

Inmed Corporation warrants this product to be free from defects in material or workmanship within 1 year from date of purchase under normal use. If fault is found, please return the equipment, freight prepaid, in its original packaging along with the purchase receipt to the address below. Inmed Corporation will repair or replace any defective parts free of charge subject to the terms and conditions stated herein.

For service, the unit is to be returned freight prepaid to:

Inmed Corporation

5 Calle Industria, Bagumbayan, Quezon City 1110, Philippines
Tel: 02.8571.1888 | www.inmed.com.ph

Please register your unit online at:

<https://inmed.com.ph/warranty.php>

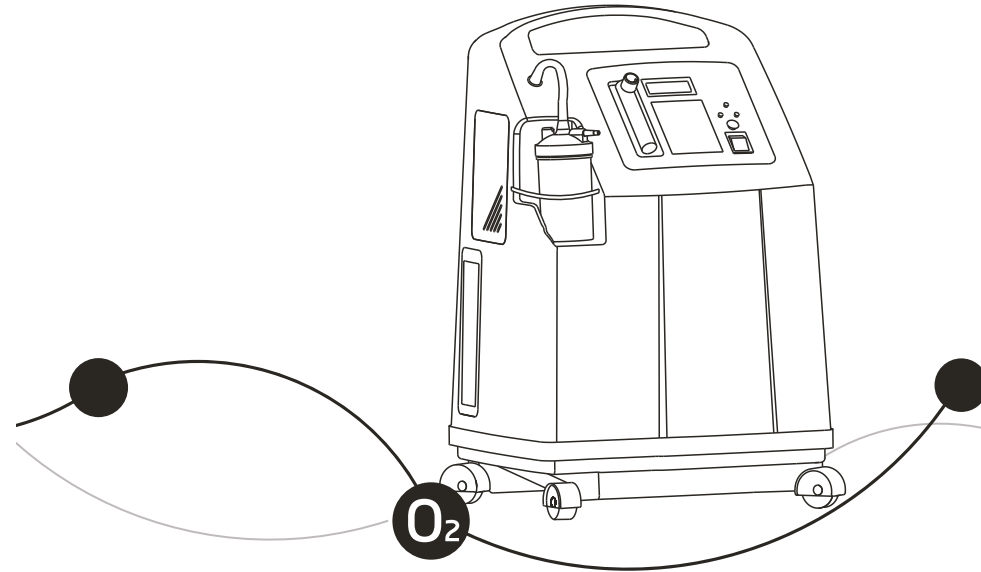

User's Manual

7F-5 Oxygen Concentrator

Please read the user's manual closely before using!

TABLE OF CONTENTS

SAFETY NOTES-----	1-4
FEATURES-----	5-7
HANDLING-----	8-8
OPERATING & INSTALLATION-----	9-13
MAINTENANCE-----	14-15
TROUBLE SHOOTING GUIDE -----	16-17
OTHER ATTENTION ITEMS-----	18-19

WARNING: For avoiding power outage or oxygen concentrator operating failure, exigent oxygen user and serious patient must equip with reserve oxygen supply (for example: oxygen cylinder, oxygen bag). This device must equip with reserved oxygen supply and is not used as life supporting or life sustaining.

BEFORE INSTALLATION

- › The concentrator should always be kept in the upright to prevent cabinet damage when transporting.
- › When the electrical source, power voltage is beyond the normal power voltage range. Please add voltage stabilizer.
- › Use eligible, safe power set and junction box.
- › Only the technician can open the oxygen concentrator's cabinet.

STRORGE PLACE

- › You may select the most suitable room when using your oxygen concentrator. Use the casters to transfer the concentrator from room to room.
- › Place the unit away from all sides for at least 10cm (4inches) from walls, draperies, furniture, or other obstruction. Do not place the unit in a confined area.

SAFETY NOTES

- ▶ Oxygen concentrator must avoid from heat, fire, moisture, exorbitant or over-low extream condition.
- ▶ Sundries and vessel should not be placed on top of the concentrator.
- ▶ NEVER block the air inlet of the unit or place it on a soft surface, such as a bed or couch, where the air inlet may be blocked. Keep the inlet free from lint, hair, etc.

USING

- ▶ The use of oxygen therapy requires that special attention to reduce the risk of fire. Users **MUST NOT SMOKE** while using this device. Keep all matches, lighted cigarettes or other sources of ignition out of the room in which this product is located. **NO SMOKING** signs should be prominently displayed. Textiles and other materials that normally would not burn are easily ignited and burn with great intensity in oxygen enriched air. Failure to observe this warning can result in severe fire, property damage and cause physical injury or **DEATH**.
- ▶ For optimum performance, do not open or turn off the concentrator frequently, reset after 3~5 minutes. Shorter periods of operation may reduce maximum product life.
- ▶ A spontaneous and violent ignition may occur if oil, grease or greasy substances come in contact with oxygen under pressure. These substances **MUST** be kept away from the oxygen concentrator, tubing and connections, and all other oxygen equipment. **DO NOT** use any lubricants unless recommended by manufacturer.

SAFETY NOTES

MAINTENANCE

Only the authorized or trained technician can perform the maintenance or adjustments to the oxygen concentrator. The manufacturer recomands each operation time shoud not be less than 30 mininutes, do not frequently press the switch in order to extend the operation life to the machine.

RADIO FREQUENCY INTERFERENCE

Most electronic equipment is influenced by Radio Frequency Interference (RFI). **CAUTION** should be exercised with regard to the use of portable communications equipment in the area around such equipment.

TO REDUCE THE RISK OF BURNS, ELECTROCUTION, FIRE OR INJURY TO PERSONS

- ▶ Avoid using while bathing. If continuous usage is required by the doctor's prescription:
The concentrator must be located in another room at least 2.5m away from the bath.
- ▶ Do not come in contact with the concentrator while wet.
- ▶ Do not place or store product where it can drop into water or other liquid.

SAFETY NOTES

- ▶ DO NOT contact the product that has fallen into water. Unplug immediately.
- ▶ A product should never be left unattended when plugged in.
- ▶ This device is to be used only in accordance with the prescription of a doctor and this user's manual. If at any time the patient or attendant conclude that the patient is receiving an insufficient amount of oxygen, the supplier and/or doctor should be contacted immediately. No adjustments should be made to the flowrate unless prescribed by a doctor.
- ▶ Close supervision is necessary when this product is used near children or individuals with disability.
- ▶ Use this product for only intended use as described in this manual.
- ▶ Do not use parts, accessories or adapters other than those authorized by manufacturer.
- ▶ Do not connect the concentrator with other oxygen concentrators or oxygen therapy devices.
- ▶ Use of some administration accessories or certain humidifiers not specified for use with oxygen concentrator may impair the performance.
- ▶ In certain circumstances oxygen therapy can be hazardous. Manufacturer recommends that you seek medical advice before using this product.
- ▶ Avoid creation of any spark near medical oxygen equipment. This includes sparks from static electricity created by any type of friction.

FEATURES

SUMMARY

The function of oxygen

- ▶ Supplying oxygen to patients can assist in the treatment of heart head blood-vessel, respiratory system, such as chronic obstructive pulmonary disease, rehabilitation and hypoxia conditions.
- ▶ Oxygen could improve body function, especially suit for elderly, pregnant women, physique, students etc. Who got physiological hypoxia. It may also reduce fatigue after heavy manual or mental consumption.

THE SCOPE OF PRODUCTS

For hospital and homecare use to supply oxygen to patients.

STRUCTURE

- ▶ The product is mainly composed of oxygen making host, flow meter, humidifier.
- ▶ Safety plastic shell.
- ▶ With time collect function: Display the operation time in LCD.
- ▶ High and low pressure alarm function.
- ▶ Power loss alarm function.
- ▶ Fault self-detection system(Include pressure fault, system cycle fault, compressor fault, low oxygen concentration detection function.).
- ▶ The compressor with thermal protector guarantee better security.

FEATURES

SPECIFICATIONS

1. Maximum recommended flow: 5L/min
2. Flow Range: 0.5~5L/min
3. Change in maximum recommended flow when back pressure of 7kPa is applied: 0.5L/min
4. Oxygen Concentration: 95.5% ~ 87%
5. Maximum Outlet Pressure: 45kPa ± 4.5kPa(6.52psi ± 0.65psi),
6. Pressure Relief Mechanism Operational at: 250kPa ± 25kPa (36.25psi ± 3.63psi)
7. Noise: ≤53dB(A),
8. Power Supply:
AC100V ± 10% AC120V ± 10% AC220V ± 10% AC230V ± 10%
50Hz 60Hz
9. Input Power: 500VA,
10. Weight: 27kg,
11. Dimension: H44.5cm (17.5") x W37.2cm (14.7") x D68cm (26.8")
12. Minimum operating time: 30minutes
13. Altitude: Up to 1828 meters (6000 ft) above sea level without degradation of concentration levels. From 1828 meters (6000 ft) to 4000meters (13129 ft) below 90% efficiency.
14. Safety system:
Current overload or loose connection, automatic shutdown.
Compressor with abnormal high temperature, automatic shutdown.
High & low pressure alarm function, automatic shutdown.
Compressor alarm function, automatic shutdown.
Low oxygen concentration alarm function.

FEATURES

15. Minimum Operating Time: 30minutes
16. Electric classification: Class II , type BF application part
17. Work system: work continuously.
18. NORMAL OPERATION CONDITIONS:
Temperature range: 10°C ~ 35°C (50°F ~ 95°F);
Relative humidity: 30% ~ 75%;
Atmosphere pressure: 860hPa ~ 1060hPa(12.47psi ~ 15.37psi);
NOTE: When storage temperature is below 5°C, please keep the equipment in normal working condition for at least 4 hours before using.
19. Temperature at oxygen outlet: ≤46°C
20. Suggestion: The length of nasal oxygen cannula should be less than 15.2 meters and should not be pinched.
21. Transportation and storage conditions:
Temperature range: -20°C ~ +60°C(- 4°F ~ +140°F),
Relative humidity: 10% ~ 93%, no condensation,
Atmosphere pressure: 700hPa ~ 1060hPa(10.15psi ~ 15.37psi).
NOTE: Oxygen concentrator should be stored without intense sunlight, no corrosive gas and in a well ventilated room, avoid jolt and inverted recumbent transport.

HANDLING

UNPACKING

- ⚠ NOTE: Unless the oxygen concentrator is to be used immediately, otherwise it should be stored in the containers until it's being used again.
- ▶ Check for any obvious damage to the carton or its contents. If damage is evident, please notify the carrier or local dealer.
 - ▶ Remove all loose packing from the carton.
 - ▶ Carefully remove all the components from the carton.

INSPECTION

- ▶ Examine exterior of the oxygen concentrator for nicks, dents, scratches or other damages. Inspect all components.

STORAGE

- ▶ Store the repackaged oxygen concentrator in a dry area.
- ▶ Do not place other objects on top of the repackaged concentrator.

OPERATING & INSTALLATION

FEATURE VIEW

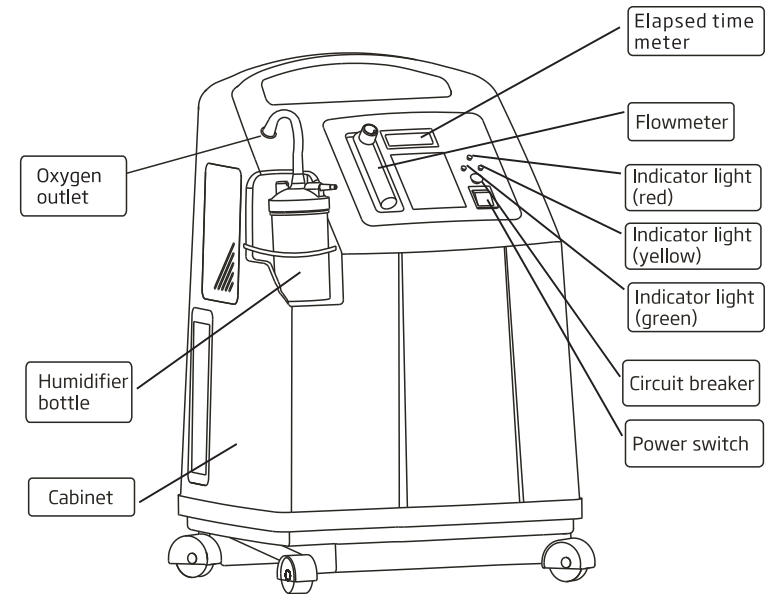

Figure 1: view of the machine

OPERATING & INSTALLATION

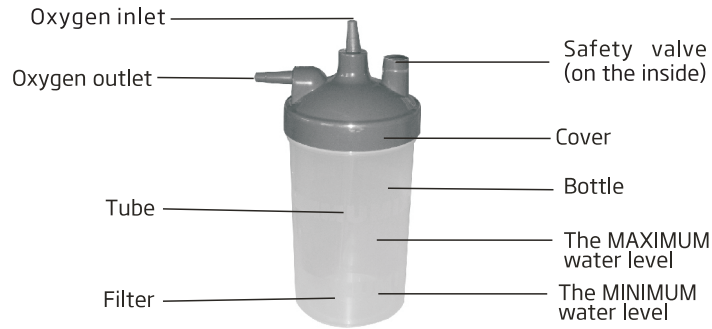

Figure 2: view of the humidifier

PREPARE WORK

- ▶ Unscrew the bottle from the humidifier counter-clockwise. Fill the bottle with pure water (or distilled water) to the level indicated by the manufacturer.
- ▶ Screw securely to the bottle back clockwise.
- ▶ Plug in: First confirm the power switch of oxygen concentrator is off, then connect the plug .
- ▶ Do not use extended power line.

OXYGEN ABSORBING OPERATION

- ▶ Turn the power switch to " | " , the LCD shows "HELLO" , green, yellow, red indicator all light indicates that the machine is normal. The green indicator lights only 1 second later. 4 seconds later, the LCD shows elapsed time, then the machine goes to normal operation.

OPERATING & INSTALLATION

- ▶ Turn the flowrate knob to require oxygen need (Reed as centre of the black ball). Turn the knob anticlockwise to increase the flowrate, and clockwise to decrease. Meanwhile, humidifier bottle will have air bubble around the sieve core. Then, oxygen comes from the oxygen outlet. (Figure 3)
- ▶ Connect the nasal oxygen cannula to the oxygen outlet of the humidifier, the other end match the patient.

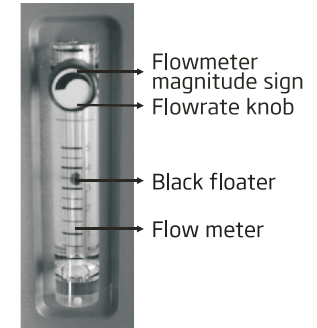

Figure 3

- ⚠ Note: Adjust the time of absorbing oxygen and the flowrate range according to the doctor's advices.
- ▶ If the humidifier makes continuous sound, it shows that the nasal oxygen cannula jammed, then please clear the pipeline.
- ▶ CAUTION: If the flowrate on the flowmeter ever falls below 0.5L/min, check tubing or accessories for blocked or kinked tubing or a defective humidifier bottle.

Alarm signal



- ▶ The machine has detection function as follows:
 - (1)Pressure, cycle failure
 - (2)Compressor failure
 - (3)Low oxygen concentration

Remarks: All alarm state of the oxygen concentrator belongs to low priority.

The oxygen sensor starts working after 5 minutes of operation. The indicator shows different colours on the basis of different ranges of oxygen concentration.

Indicator interpretation

OPERATING & INSTALLATION

Symbol	Statement	Indicator
I/O	System is in good condition: oxygen concentration $\geq 82\% (+3\%)$	Green
	$50\% (\pm 3\%) \leq$ oxygen concentration $< 82\% (+3\%)$	Green, Yellow
	System failure 1) oxygen concentration $< 50\% (\pm 3\%)$ 2) Pressure, cycle failure alarm 3) Compressor failure alarm	Red

▸ The alarm signal

1. When oxygen concentration $\geq 82\% (+3\%)$ the green indicator lights, LCD shows elapsed time, the machine is in good condition.
2. When $50\% (\pm 3\%) \leq$ oxygen concentration $< 82\% (+3\%)$ the green indicator and yellow indicator light both, LCD shows elapsed time, Please contact the supplier immediately. Users can continue to use, and please ensure that backup oxygen is nearby.

NOTE: The minimum operating time is 30 minutes











3. When oxygen concentration $< 50\% (\pm 3\%)$ the red indicator lights with continuous audible alarm sound, LCD shows "LO", machine stops working. Please shut down immediately and use backup oxygen, and contact the supplier immediately.
4. Pressure, cycle failure alarm--the red indicator lights with continuous alarm sound, LCD shows "E1 or E2" machine stops working. Please shut down immediately and use backup oxygen, and contact the supplier immediately.
5. Compressor failure alarm--the red indicator lights with continuous alarm sound, LCD shows "E3 or E4", machine stops working. Please shut down immediately and use backup oxygen, and contact the supplier immediately.

OPERATING & INSTALLATION

TURNING OFF

- Take off nasal oxygen cannula from oxygen outlet first, close power switch, and then cut off power source.

SYMBOLS

Symbol	Description	Symbol	Description
	Alternating current		Consult the manual
	Class II Equipment		Type BF application part
	OFF(power, disconnection from the mains)		ON(power, connection to the mains)
	NO SMOKING		KEEP UP
	FRAGILE		KEEP DRY
	STACKING LIMITATION		

MAINTENANCE

⚠ WARNING: CUT OFF the power supply first. To avoid electrical shock, DO NOT remove cabinet.

CLEANING CABINET

- Clean the cabinet with a mild household cleaner and non-abrasive cloth or sponge at least one time each month.

CLEANING OR REPLACING FILTER

Please clean and replace the filter in time, it's very important to protect compressor and delay machine's life.

⚠ CAUTION: DO NOT operate the concentrator without the filters installed.

- Clean the I-stage filter once half a month. I-stage filter can be taken out of the foreside panel. (Figure 4)



Figure 4

The I-stage filter is in the both side of the machine, you can pull out it directly.

MAINTENANCE

- Replace the II-stage filter once a month.

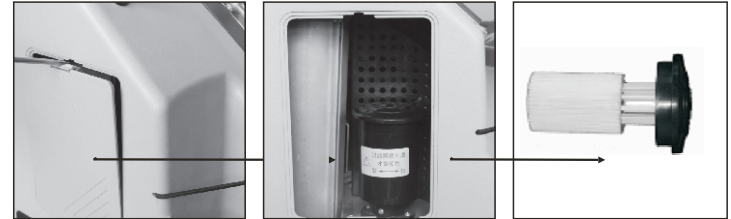

Figure 5

Figure 6

Figure 7

1. Open filter access door.(Figure 5)
2. Unscrew the filter corn.(Figure 6)
3. The frequency for replacing the II-stage filter mesh depends on practically using and condition. If the filter core turns black, please replace it at once, no matter how long it used.(Figure 7)

CLEANING HUMIDIFIER

- Change the water in humidifier bottle every day.
- Clean humidifier once a week with soapy water and rinse it with a solution of water and vinegar(10:1). Rinse thoroughly with warm water and refill with pure water (or distilled water) to the level shown on the humidifier. (NOTE: No blobs in oxygen tubing)

TROUBLE SHOOTING GUIDE

Symptom	Probable reasons	Solution	Remark
Press the switch, the concentrator is alarm of continuous buzzer but no display and working.	1)Power cord NOT plugged in	1)Insert plug into outlet	Repairs by qualified personnel
	2)No power at outlet	2)Use normal power	
	3)The power is no sufficient at outlet	3)Do not use extended cord	
	4)Raise circuit breaker	4)Press it	
	5)If this state continues, stop using the concentrator and get in touch with the supplier at once.		
Concentrator is working, but oxygen from outlet is little or no	1)Humidifier leaked	1)Reinstall and tighten it	
	2)Safety valve of humidifier opens	2)Safety valve restoration	
	3)The connection of the tubes loosened	3)Insert tubes	
	4)The nasal cannula kinked or blocked	4)Replace it	
Concentrator is working, green with yellow light illuminate	1)50% ≤ oxygen concentration < 82%	1)Clean or replace the filter	
	2)Oxygen flow rate is more than maximum flow	2)Complied doctor's advice, turn the flowmeter to the given value	
	3)If this state continues, you may continue to use the concentrator, Contact the supplier at once.		
Concentrator is alarm and not working, the red light illuminate, the display screen shows "LO"	1)Oxygen concentration < 50%	1)Clean or replace the filter	
	2)Oxygen flowrate is more than maximum flow	2)Turn off the concentrator and on it again, turn the Flowmeter to the given value	
	3)If this state continues, stop using the concentrator and get in touch with the supplier at once.		
Concentrator is alarm and not working, the red light illuminate, the display screen shows "E1"	1)Low cycle pressure failure	1)Clean or replace the stage filter	
	2)If this state continues, stop using the concentrator and get in touch with the supplier at once.		

TROUBLE SHOOTING GUIDE

Symptom	Probable reasons	Solution	Remark
Concentrator is alarm and not working, the red light illuminate, the display screen shows "E2"	1)High cycle pressure failure	1)Stop using the concentrator and get in touch with the supplier at once	
Concentrator is alarm and not working, the red light illuminate, the display screen shows "E3"	1)Compressor circuit is open circuit	1)Stop using the concentrator and get in touch with the supplier at once	
Concentrator is alarm and not working, the red light illuminate, the display screen shows "E4"	1)Compressor circuit is short circuit	1)Stop using the concentrator and get in touch with the supplier at once	
The nasal cannula has more mirage or blobs	1)It's not ventilate completely around machine, so operating temperature is too high	1)Make sure the machine is at least 10cm away from the walls, other jam or heater	
	2)Temperature of the water added in humidifier bottle is overhigh	2)Add cold water in bottle, but don't add overhot water	
	3)The water added in humidifier bottle is too much	3)Make sure the water stays between the maximum and minimum of the water scale	
	4)The machine stops suddenly during breathing oxygen	4)Stop breathing oxygen immediately, Restart the machine to eject the hydrosphere	
	5)The machine stops suddenly when folding the nasal cannula	5)Smooth the nasal cannula	
	6)Fan inside the machine can't run or running rate turns slow make the operating temperature overhigh	6)a.Take out the eyewinker that lock the fan 6)b. Replace it	Repairs by qualified personnel

⚠ If you have all other problems, TURN OFF the concentrator first, use your reserve oxygen supply (if provided) and contact dealer or manufacturer immediately.

OTHER ATTENTION ITEMS

GAS PASS OPERATION SKETCH MAP:

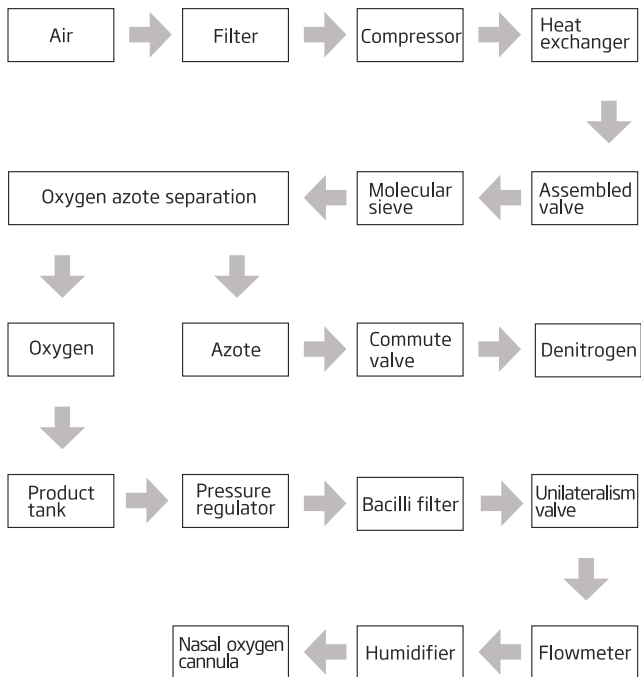

OTHER ATTENTION ITEMS

ELECTRICAL RATIONALE

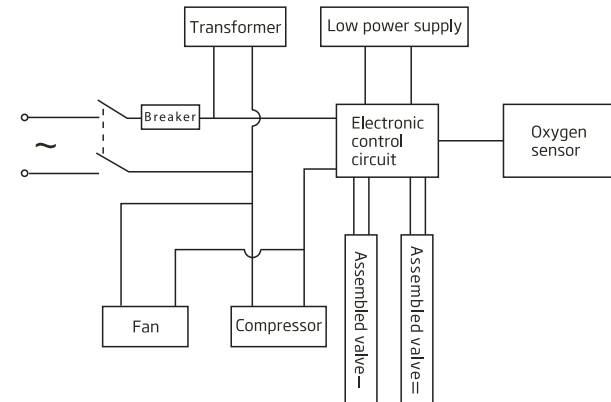

ACCESSORIES LIST

1. Nasal oxygen cannula	1 set
2. User's manual	1 piece
3. Filter core	1 set

All specifications and product configurations are subject to change without notification.